

# **EBS-40**

**Base station**

ESL base station

## **Specifications manual**



All information subject to change without notice.

## Document History

<b>Model Number:</b>	EBS-40	<b>Revision nr:</b>	3
<b>Changes:</b>	Update of radio spec		
<b>Date:</b>	07-08-2023		

## Copyright 2015 Opticon. All rights reserved.

This manual may not, in whole or in part, be copied, photocopied, reproduced, translated or converted to any electronic or machine readable form without prior written consent of Opticon.

## Limited Warranty and Disclaimers

PLEASE READ this manual CAREFULLY before installing or using the product.

## Serial Number

A serial number appears on all Opticon products. This official registration number is directly related to the device purchased. Do not remove the serial number from your Opticon device. Removing the serial number voids the warranty.

## Warranty

Unless otherwise agreed in a written contract, all Opticon products are warranted against defects in materials and workmanship for two years after purchase. Opticon will repair or, at its option, replace products that are defective in materials or workmanship with proper use during the warranty period. Opticon is not liable for damages caused by modifications made by a customer. In such cases, standard repair charges will apply. If a product is returned under warranty and no defect is found, standard repair charges will apply. Opticon assumes no liability for any direct, indirect, consequential or incidental damages arising out of use or inability to use both the hardware and software, even if Opticon has been informed about the possibility of such damages.

## Packaging

The packing materials are recyclable. We recommend that you save all packing material to use should you need to transport your scanner or send it for service. Damage caused by improper packaging during shipment is not covered by the warranty.

## Trademarks

Trademarks used are the property of their respective owners.

Opticon Inc. and Opticon Sensors Europe B.V. are wholly owned subsidiaries of OPTOELECTRONICS Co., Ltd., 12-17, Tsukagoshi 4-chome, Warabi-shi, Saitama, Japan 335-0002. TEL +81-(0) 48-446-1183; FAX +81-(0) 48-446-1184

---

## SUPPORT

### USA

Phone: 800-636-0090

Email: [support@opticonusa.com](mailto:support@opticonusa.com)

Web: [www.opticonusa.com](http://www.opticonusa.com)

### Europe

Email: [support@opticon.com](mailto:support@opticon.com)

Web: [www.opticon.com](http://www.opticon.com)

---

## Contents

1. Abstract.....	6
2. Overview.....	6
3. Physical Features.....	7
3.1. Dimensions.....	7
3.2. Weight.....	7
4. Environmental Specifications.....	8
4.1. Operating Temperature and Humidity.....	8
4.2. Storage Temperature and Humidity.....	8
4.3. Static Electricity.....	8
4.4. Drop resistance.....	8
4.5. Dust and Drip Proof.....	8
5. Controls.....	9
6. Electrical Specifications.....	9
6.1. Electrical Characteristics.....	9
7. Radio Specifications.....	10
7.1. Protocol.....	10
7.1.1. The physical layer.....	10
7.1.2. The medium access control layer.....	10
7.2. Security.....	10
8. Labeling.....	11
8.1. Product label.....	11
8.2. White box label.....	12
9. Packaging Specifications.....	13
9.1. Individual Packaging Specification.....	13
9.2. Collective Packaging Specification.....	14
10. Accessories.....	15
11. Regulatory Compliance.....	16
11.1. Product Safety.....	16
11.2. EMC.....	16
11.3. RoHS.....	16
12. Safety.....	17
12.1. Shock.....	17

12.2.	Temperature Conditions .....	17
12.3.	Foreign Materials.....	17
12.4.	Other .....	17
13.	Mechanical Drawing .....	18

## Table of Figures

<a href="#">Figure 1: Dimensions</a>	7
<a href="#">Figure 2: product label</a>	11
<a href="#">Figure 3: shipment box label</a>	12
<a href="#">Figure 4: Individual Packing</a>	13
<a href="#">Figure 5: Collective packaging</a>	14
<a href="#">Figure 6: DIN rail to mount the EBS-40.</a>	15
<a href="#">Figure 7: Mechanical drawing</a>	18

## 1. Abstract

This manual provides specifications for the EBS-40 base station that can serve Opticon's electronic shelf labels. (Hereafter referred to as "Base station").

## 2. Overview

The EBS-40 is a base station, equipped with two 2.4GHz radios for data communication with Opticon's electronic shelf labels. This product uses Direct Sequence Spread Spectrum RF technology that allows for an ultra-low power consumption combined with a reduced sensitivity to background noise. That means less interference by other radios that operate in the 2.4GHz band. The radio protocol that is used is based on the IEEE 802.15.4 standard that specifies the physical layer and media access control for low-rate wireless personal area networks.

The base station provides the link between a back office system and the ESLs. The base station is equipped with an Ethernet interface so that it can connect to a local area network. It has a two port Ethernet switch built-in that allows for easy daisy chaining, enabling simplified network cabling.

## 3. Physical Features

### 3.1. Dimensions

W 145.1 x H 110.1 x D 32.4 mm (without antennas)

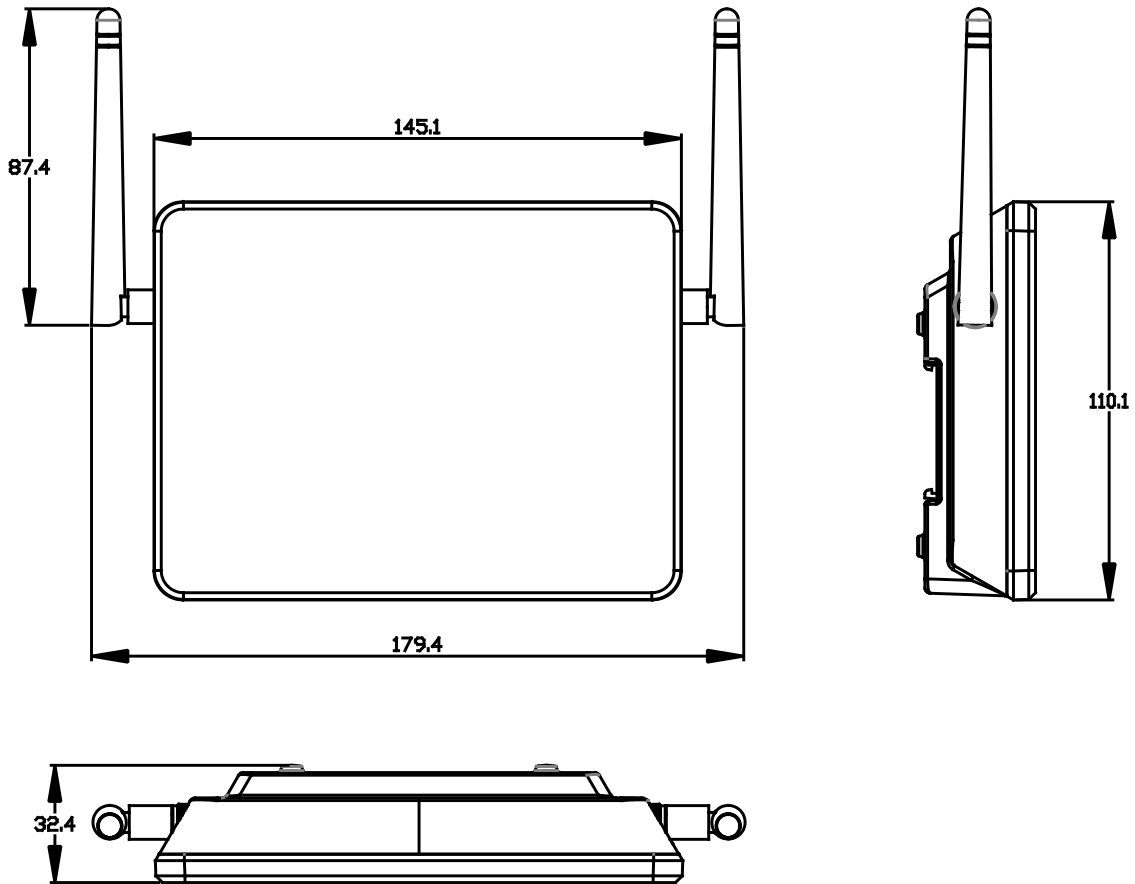

Figure 1: Dimensions

### 3.2. Weight

250 g (including antennas)

## 4. Environmental Specifications

### 4.1. Operating Temperature and Humidity

Temperature: -10 to 50° C

Humidity: 20% to 85% RH

### 4.2. Storage Temperature and Humidity

Temperature: -20 to 60° C

Humidity: 20% to 85% RH

### 4.3. Static Electricity

Air discharge:                    ± 8 kV MAX (No malfunction / Automatic recovery)  
   ± 15 kV MAX (No destruction)

Contact discharge:            ± 4 kV MAX (No malfunction / Automatic recovery)  
   ± 8 kV MAX (No destruction)

### 4.4. Drop resistance.

This product has not undergone drop tests and it therefore has no drop test rating.

### 4.5. Dust and Drip Proof

This product will not have an IP rating. The intended use is indoor only.



## 5. Controls

Items	Specifications		Remarks
CPU	Type	Cortex M4F processor core	
	Internal flash ROM	512 Kbyte	
	Internal RAM	256 Kbyte	
	External RAM	8 MByte	
	Clock frequency	120 MHz	
Ethernet Interface	Speed	10 Mbit/sec & 100 Mbit/s	
	Operation mode	Half duplex & Full duplex	
	Nr of ports	2	
Radio	Modulation	DSSS	
	Frequency	2405 + 5(C-11) MHz Channel 11-26	Channels 27~28 are available on request. <sup>2</sup>
	Baud rate	250 Kbits / second	

<sup>1</sup>Channels 1~10 are reserved for sub-GHz frequencies, which are not supported by the EBS-50.

<sup>2</sup>Local regulations may not allow the use of these channels.

## 6. Electrical Specifications

### 6.1. Electrical Characteristics

Parameter	Min	Typ	Max	Remarks
Operating voltage	4.5 V		6.6 V	
Operating current		250 mA		Both Ethernet ports connected. Operating voltage 6V

## 7. Radio Specifications

Parameter	Min	Typ	Max	Unit	Remarks
Receiver sensitivity		-97	-89	dBm	Over the entire temp. and operating voltage range
Nominal output power	-1.9		-1.6	dBm	
Frequency	2405		2405 + 5(C-11)	MHz	Over the entire temp. and operating voltage range
Transfer rate		250Kbit/s			
RSSI range		100		dB	Signal strength indication that can be reported to the base station

### 7.1. Protocol

Modified 802.15.4 (Physical layer and Media Access Control layer).

#### 7.1.1. The physical layer

The physical layer (PHY) provides the data transmission service, as well as the interface to the physical layer management entity, which offers access to every layer management function and maintains a database of information on related personal area networks. Thus, the PHY manages the physical RF transceiver and performs channel selection and energy and signal management functions. It operates on the above mentioned frequency band. The PHY layer is 100% compliant and is based on direct sequence spread spectrum (DSSS) technique with a transfer rate of 250 kbit/s.

#### 7.1.2. The medium access control layer

The medium access control (MAC) layer enables the transmission of MAC frames through the use of the physical channel. Besides the data service, it offers a management interface and itself manages access to the physical channel. It also controls frame validation, guarantees time slots and handles node associations. Finally, it offers hook points for secure services. The EE200 does not make use of the optional network beaconing, instead it used a polling mechanism to increase power efficiency. Some changes are made to the standard to allow for more efficient data frames and better power efficiency, especially when nodes are not connected to a base station.

### 7.2. Security

The 802.15.4 standard 128-bit AES encryption is supported. A secure method for key management is implemented as well. The encryption is available on request. By default the radio traffic is unencrypted.

## 8. Labeling

### 8.1. Product label

The product label shown below is affixed to the back side of the base station.



Figure 2: product label

The label shows two barcodes; on top is the Ethernet MAC address and below is the serial number of the base station. The MAC address shown here matches the actual address programmed into the EBS-40.

The addresses for the two 802.15.4 radios are derived from this address. These addresses (both are the same) are essentially the same as the Ethernet address, but with two zero's. Below is a description of those addresses:

Ethernet MAC address:  $M_1M_2M_3-S_1S_2S_3$

802.15.4 MAC address:  $M_1M_2M_3-S_aS_bS_1S_2S_3$

$M_1M_2M_3$  Define the manufacturer ID, which is 00126A in our case and is the same for both address types. The bytes that following the manufacturer ID, define the product number and that number is 3 bytes long for an Ethernet address and 5 bytes for a 802.15.4 address. To convert the two, we have set  $S_aS_b$  both to zero. So e.g. an Ethernet MAC address of 00126A45AB23 results in an 802.15.4 address of 00126A000045AB23

Material: Base + laminate protection against wear.  
 Base: PP film, thickness 80µm, backing with glue.  
 Laminate: PET film, clear, thickness 50µm.  
 Colors: Black & White

The dimensions of the product label are W 84 x H 32.

## 8.2. White box label

The white box label is made from plain paper and is meant to show the product number and serial number. The label design is shown below.

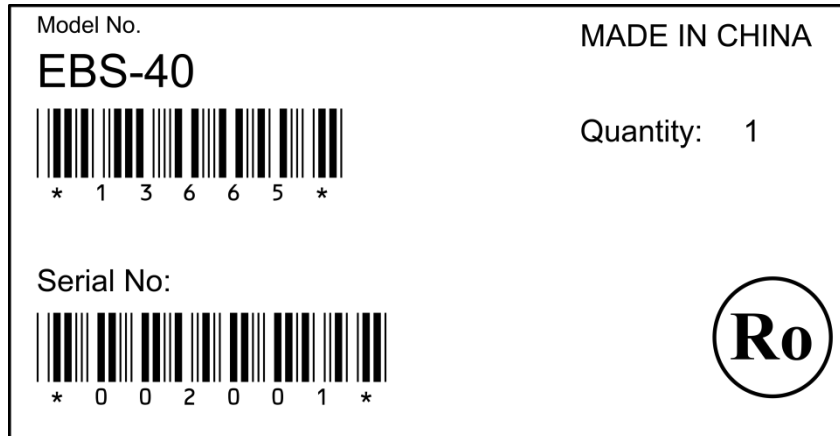

Figure 3: White box label

The Size is 60mm x 25mm with a tolerance of  $\pm 2$  mm

Label material: Paper, white, with permanent adhesive backing.

Article number: Standard code 39 + human readable text

Serial number: Standard code 39 + human readable text, data should match that of the product inside the box.

## 9. Packaging Specifications

### 9.1. Individual Packaging Specification

After putting a scanner in a foam bag, pack it in a separate box with the accessories:

- Two antennas
- One quick start guide

Put a label on the side of the individual packing box.

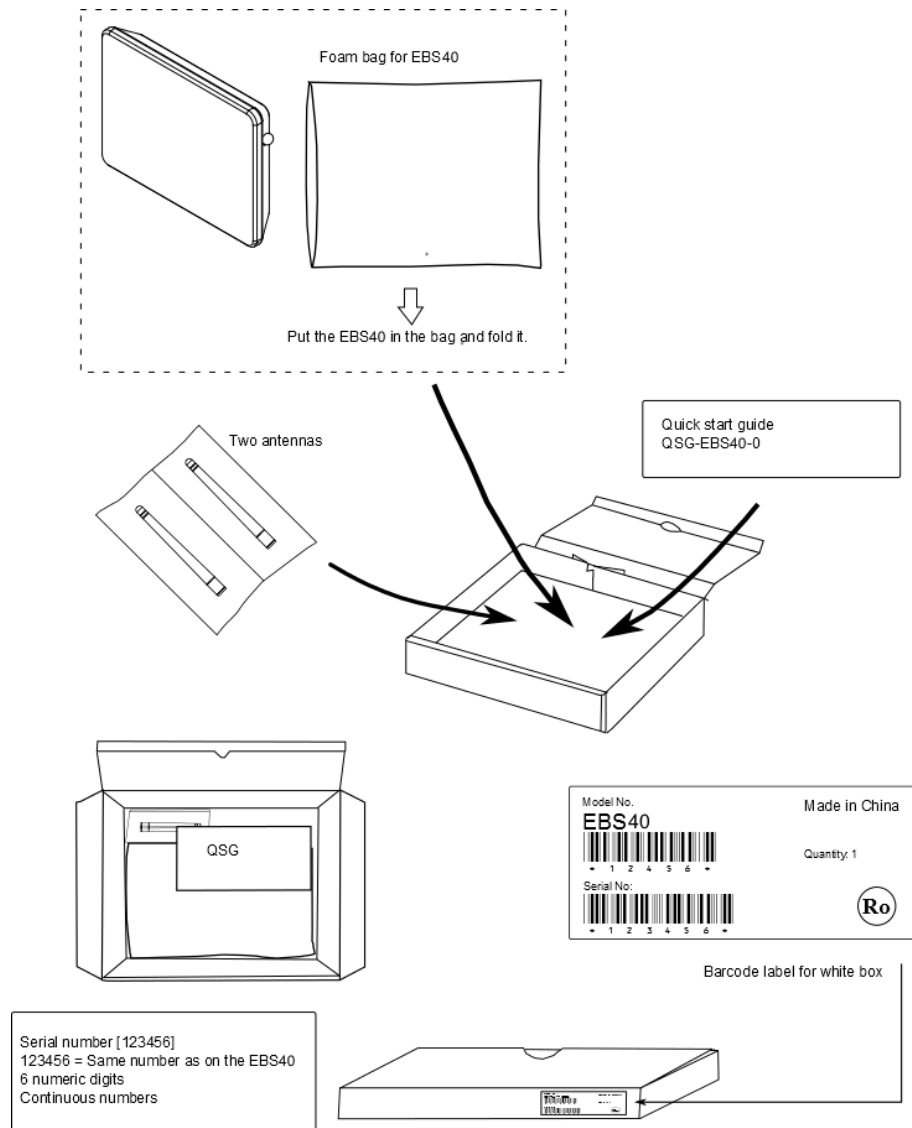

Figure 4: Individual Packing

## 9.2. Collective Packaging Specification

Put 24 individual boxes with a base station inside a box.

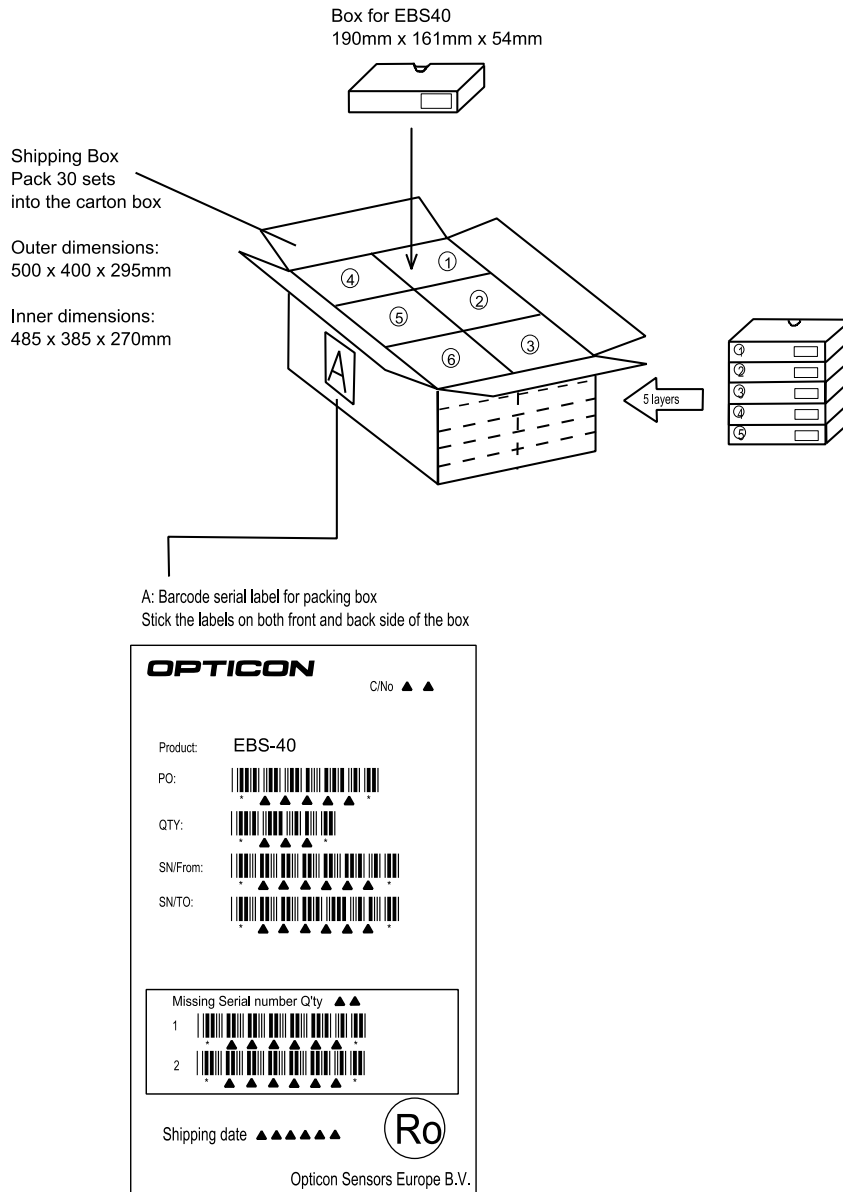

Figure 5: Collective packaging

**Note:** The “RO” mark labeled on the package tray or package box guarantees that the applicable product has passed our test of RoHS restrictions compliance (the restriction of the use of certain hazardous substances in electrical and electronic equipment, 2002/95 EC). However, this document does **not** have any legal weight in the European Union.

## 10. Accessories

To mount the base station to e.g. a wall or onto the ceiling, a standard DIN rail can be used. This is a standard product and can be purchased through Opticon but is also commonly available in the market.

The DIN rail that fits the EBS-40 is 35mm wide and 7.5mm high and is available in many different lengths. The minimum length for the EBS-40 is 100mm.

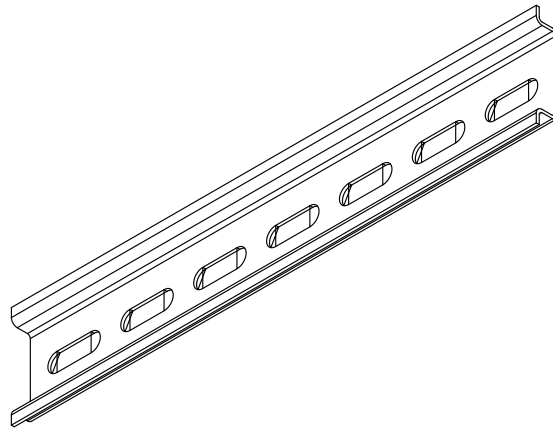

*Figure 6: DIN rail to mount the EBS-40.*

## 11. Regulatory Compliance

### 11.1. Product Safety

EN60950-1:2001

IEC60950-1:2001

### 11.2. EMC

EN55022

EN55024

FCC Part 15 Subpart B Class B

This device complies with part 15 of the FCC Rules.

Operation is subject to the following two conditions:

( 1 ) this device may not cause harmful interference, and

( 2 ) this device must accept any interference received, including interference that may

FCC Part 15 Subpart C Clause 247 (Spread spectrum radio systems)

### 11.3. RoHS

RoHS: The restriction of the use of certain hazardous substances in electrical and electronic equipment, 2002/95 EC.



## **12. Safety**

Handle this product carefully. Do not deliberately subject it to any of the following.

### **12.1. Shock**

Do not throw or drop the base station.

Do not place heavy objects on the base station.

### **12.2. Temperature Conditions**

Do not use the base station at temperatures outside the specified range.

Do not pour boiling water on the base station.

Do not leave the base station on the dashboard of a car.

### **12.3. Foreign Materials**

Do not immerse the base station in liquids.

Do not subject the base station to chemicals.

### **12.4. Other**

Do not disassemble this product.

The base station may be damaged by high voltage discharges.

## 13. Mechanical Drawing

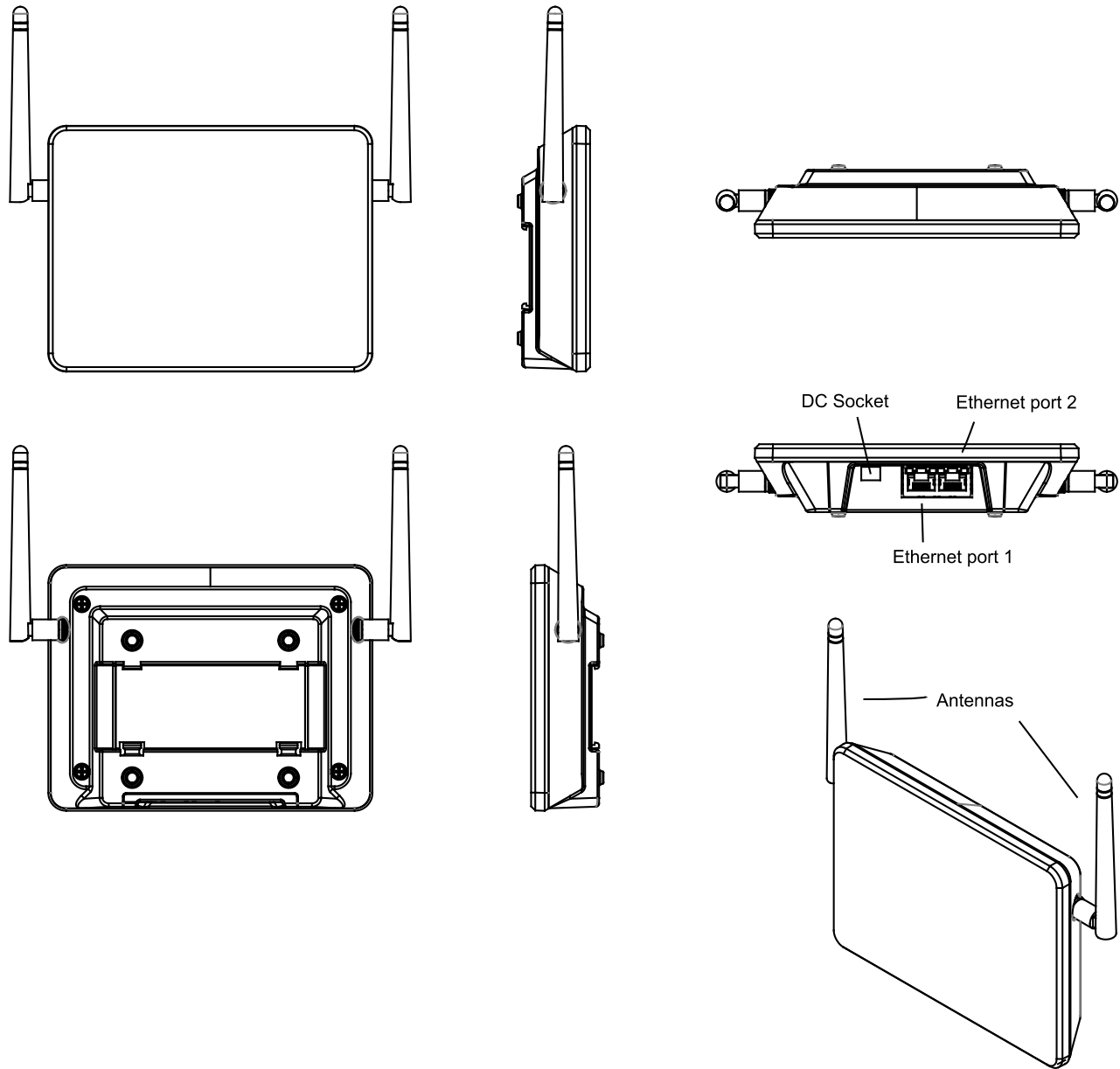

Figure 7: Mechanical drawing